

Sortie des cables Gauche vue bout d'arbre en STD
 Acces regulateur Droite vue bout d'arbre en STD
 Output power on left hand side view DE standard
 Access to regulator on right hand side view DE standard

Pre perçage Ø21 Ø25 Ø32 Ø40 Ø50
 Predrilling

Acces regulateur
 Access to regulator

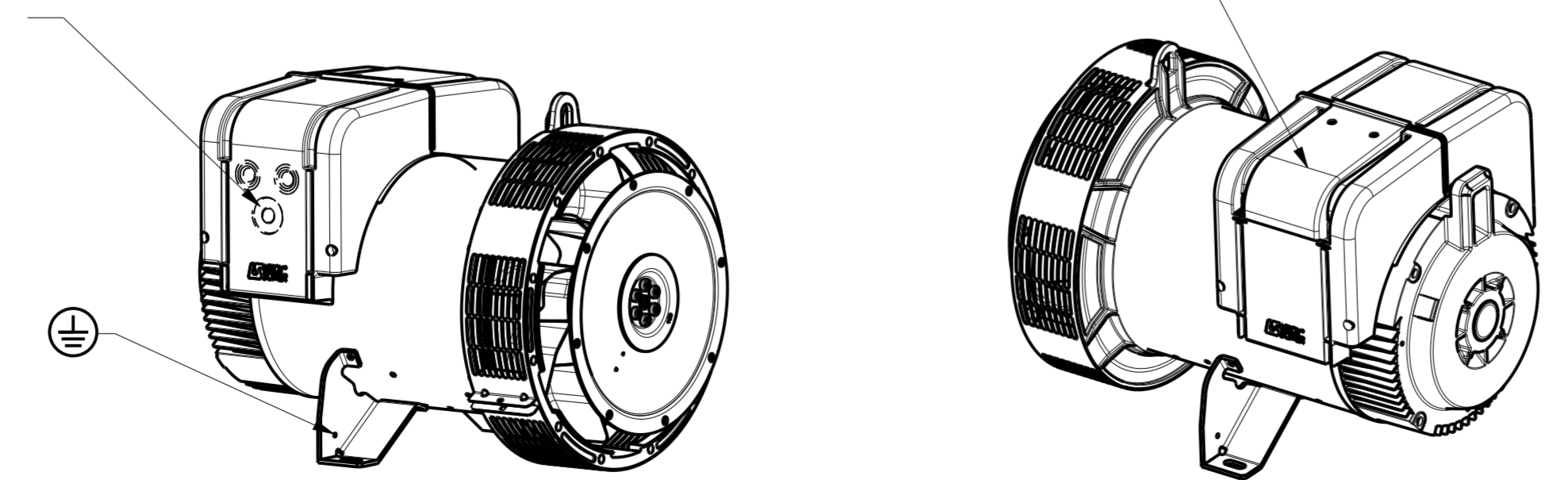

ECHELLE 0,125

ECHELLE 0,125

d	14/12/2011	cote 616 ==> 618	11-586	JMD	-	-
c	10/10/2011	Ajout tolérances sur Ø 409.58	11-453	JMD	AR	SM
b	19/09/2011	Turbine 11 pales ==> 8 pales	11-412	JMD	AR	SM
a	X	X	11-346	X	X	X
INDICE	DATE	NATURE DE LA MODIFICATION	N° C.T.	NOM	VERIF B.E.	VERIF METH
Tolerances generales: - generale			Etats de surfaces (NFE 05-016) Ra: - partout sauf indications			
Ref: -			Echelle Machine: ALTERNATEUR ALTERNATOR			
Obs: SAE 3 - 11 1/2 H=225 - L9			0,250 LSA423			
Matiere:			Designation: ENCOMBREMENT			
Modele de base: -			OUTLINE			
Variante: -			MOTEURS LEROY-SOMER 16015 ANGOULEME - FRANCE			
Composant: -						
Compose: -						
Dessine: Debord		Verif methodes				
Verifie: AR		S MAROT				
Date: 25/07/11		25/07/2011				
A2			LSA423-8-067			